

THIS DRAWING IS UNPUBLISHED. RELEASED FOR PUBLICATION
 © COPYRIGHT BY TYCO ELECTRONICS CORPORATION. ALL RIGHTS RESERVED.

LOC	DIST	REVISIONS			
P	LTR	DESCRIPTION	DATE	DWN	APVD
DF	A0				
	R	REV PER 0H14-0894-04	1-11-05	CT	LO

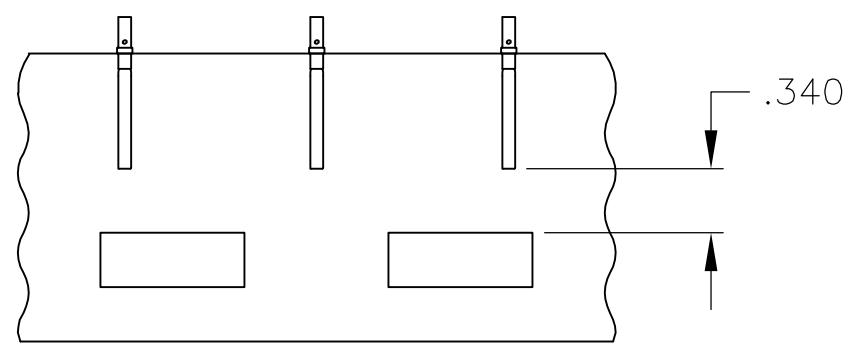

DETAIL A
 TAPE MOUNTED
 ASSEMBLY
 SCALE 1:1
 205116-2 ONLY

- WHEN ORDERING CONTACT ON TAPE, ORDER BY THE TAPE NUMBER PLUS THE PACKAGING CODE AS FOLLOWS:
 - FOR USE WITH AMP TAPETRONIC, PNEUMATIC TOOL-
 - 1000 PARTS TO A BOX ADD PACKAGING CODE: 1MBOX
 - FOR USE WITH 4/8 INDENT STRIPPER CRIMPER-
 - 1000 PARTS TO A REEL ADD PACKAGING CODE: 1MREEL
 - 5000 PARTS TO A REEL ADD PACKAGING CODE: 5MREEL
- POINT OF PLATING THICKNESS MEASUREMENT .100/.150 FROM WIRE BARREL END ON EXTERIOR.

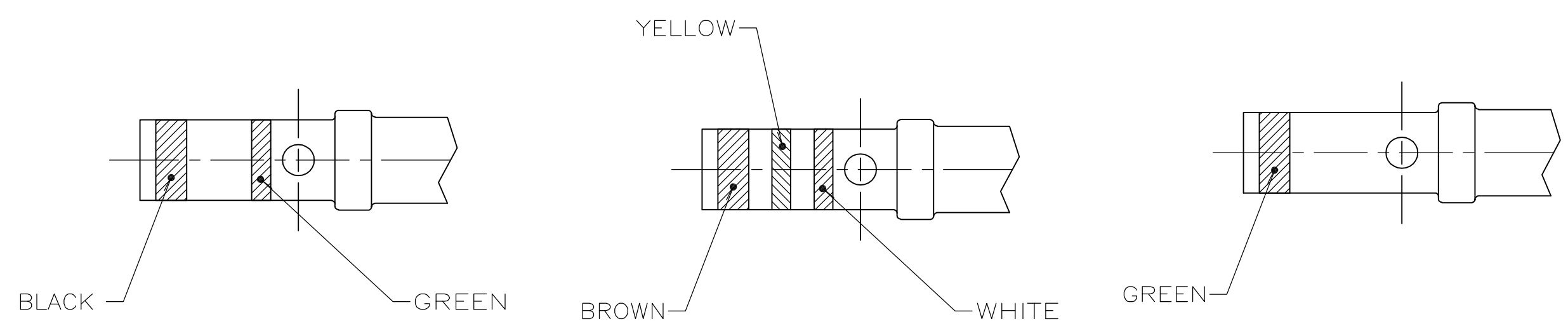
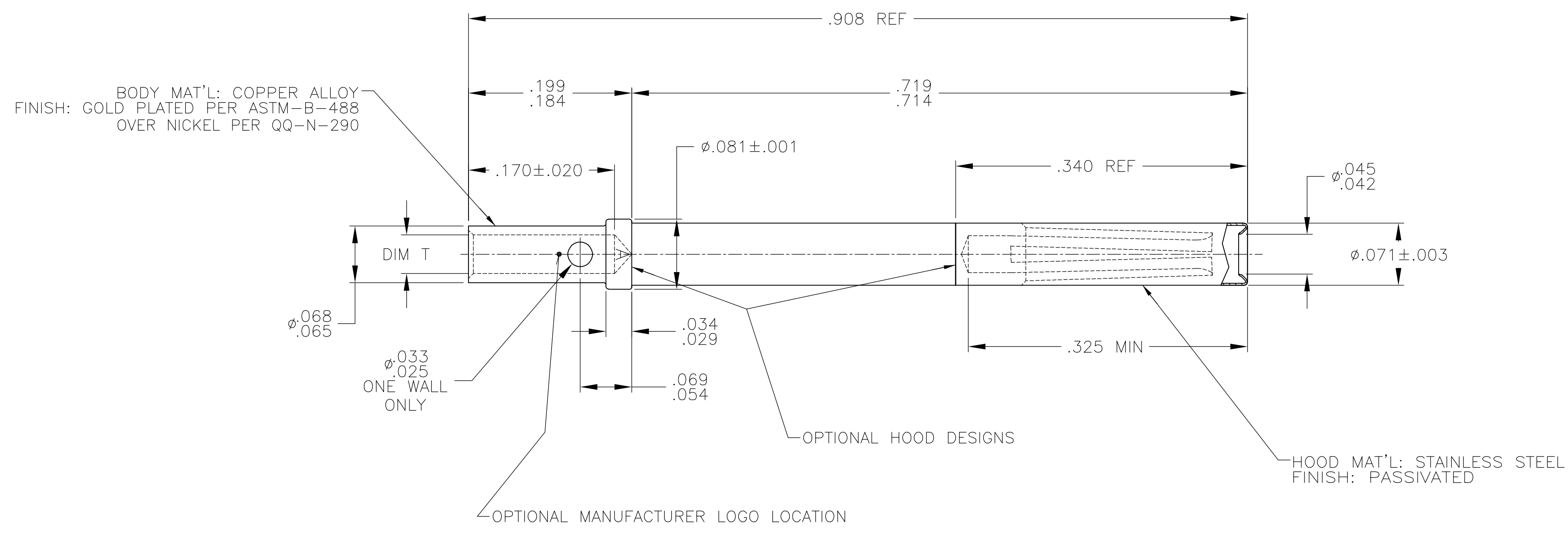

DETAIL D
 205116-5 ONLY

DETAIL B
 205116-1 & -2 ONLY

DETAIL C
 205116-4 ONLY

WIRE GAGE	REMARKS	DIM T	PART NUMBER
30 - 26	SEE DETAIL D	ø.023-.025	205116-5
24 - 20	SEE DETAIL C	ø.043-.046	205116-4
24 - 20	NO COLOR CODE	ø.043-.046	205116-3
24 - 20	SEE DETAIL A & B	ø.043-.046	205116-2
24 - 20	SEE DETAIL B	ø.043-.046	205116-1

THIS DRAWING IS A CONTROLLED DOCUMENT.		DWN C.C.THOMAS 2-12-04	Tyco Electronics Corporation Harrisburg, Pa 17105-3608	
DIMENSIONS: INCHES		CHK LARRY OH 2-12-04		
TOLERANCES UNLESS OTHERWISE SPECIFIED:		APVD LARRY OH 2-12-04	NAME SOCKET ASSEMBLY, SUB 20, TYPE XVII-RM	
0 PLC ± - 1 PLC ± - 2 PLC ± - 3 PLC ± .005 4 PLC ± - ANGLES ± 2°		PRODUCT SPEC	RESTRICTED TO	
MATERIAL SEE CALLOUTS		FINISH SEE CALLOUTS	WEIGHT -	SIZE A2
CUSTOMER DRAWING		SCALE 10:1	CAGE CODE 00779	DRAWING NO C=205116
			SHEET 1 OF 1	REV R